



TX9559

Features

- Wide Input Voltage from 9V to 40V
- Up to 8A Output Current for TX9559
- Adjustable Output Voltage up to 6V
- High Efficiency Up to 93%
- Dual Outputs with Independent Over Current Protection (OCP)
- 7.5% Accurate OCP
- Internal Soft-Start
- Auto Recovery into Full Load after Faults
- Output Cord Voltage Drop Compensation
- Programmable Over Current Setting
- Output Over-Voltage Protection
- Over-Temperature Protection
- Thermal Enhanced TSSOP14, QFN4*4-16L Package
- ROHS Compliant

Applications

- Dual-Port Car Charger
- Automotive Industry
- DVD, LCD Displays

General Description

TX9559 are monolithic step-down switch mode converters with a built-in high-side power MOSFET and a gate driver for a low side external power MOSFET. They achieve 6A continuous output current over a wide input supply range with excellent load and line regulation. Current mode operation provides fast transient response and eases loop stabilization. The

converter can be configured as single output or dual outputs with independent over current protection (OCP). Fault condition protections include cycle-by-cycle current limit and thermal shutdown. TX9559 are available in TSSOP14, QFN4*4-16L packages, provide very compact system solution and good thermal conductance.

Typical Application

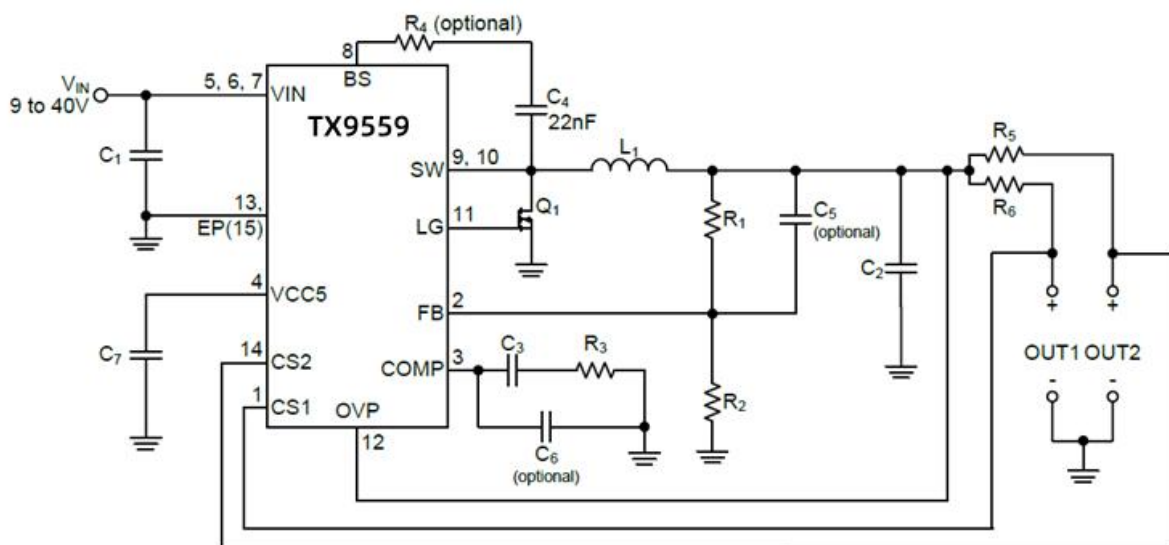

Figure 1 Simplified Application Circuit



System Block Diagram

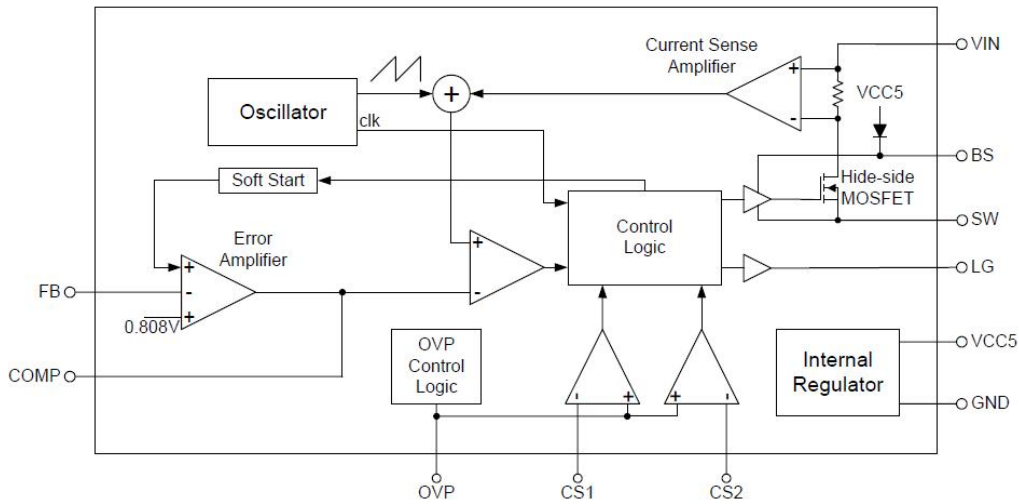

Figure 2 TX9559 Functional Block Diagram

Function Description

TX9559 are constant frequency current mode step-down DC/DC converter with synchronous gate driver. They regulate input voltage from 9V to 40V, down to an output voltage as low as 1V, and can provide up to 8A of continuous load current.

Control Loop

During normal operation, the output voltage is sensed at FB pin through a resistive voltage divider and amplified through the error amplifier. The voltage of error amplifier output pin – COMP is compared to the switch current to controls the RS latch. At each cycle, the high side NMOS would be turned on when the oscillator sets the RS latch and would be turned off when current comparator resets the RS latch. When the load current increases, the FB pin voltage drops below 0.808V, it causes the COMP voltage increase until average inductor current arrive at new load current.

Input Under Voltage Lockout

When TX9559 power on, the internal circuits are held inactive until VIN exceeds the input UVLO threshold voltage. And the regulator will be disabled when VIN below the input UVLO threshold voltage.

Over Current and Short Circuit Protection

CS pins are connected to the high side of current sensing resistors to prevent output over current With

independent CS1 and CS2 pins, two output currents are detected. If the voltage at either CS resistors exceeds 116mv for more than 750µs, the converter shuts down and goes into sleeping mode. A new startup is triggered after 2.5s. If the fault condition is not removed, the converter shuts down again until over current condition is cleared. TX9559 also provide short circuit protection function to prevent the device damage from short condition. When the output short to ground, the oscillator frequency is reduced to prevent the inductor current increasing beyond the current limit. With this long-waiting-time hiccup mode, the power consumption at over loading or outputs shot is reduced to nearly zero.

Over Temperature Protection

TX9559 incorporate an over temperature protection circuit to protect itself from overheating. When the junction temperature exceeds the thermal shutdown threshold temperature, the regulator will be shutdown.

Compensation

The stability of the feedback circuit is controlled through COMP pin. The compensation value of the application circuit is optimized for particular requirements. If different conversions are requires, some of the components may need to be changes to ensure stability.



Pin Configuration

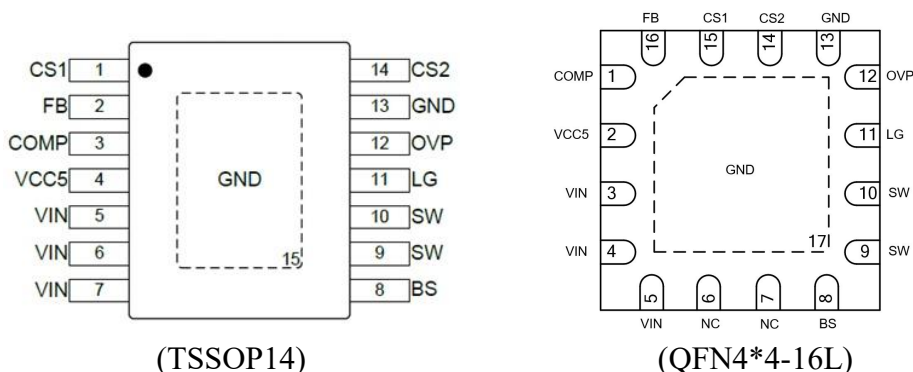

Pin Function Description

Package Pin		Pin Name	Pin Description
TSSOP14L	QFN4×4-16L		
1	15	CS1	The output current of V_{OUT1} is sensed by this pin. When the voltage on this pin is over output 116mV for 750 μ s, the IC shuts down for 2.5 seconds before initiating a re-startup.
2	16	FB	Voltage Feedback Input Pin. Connecting FB and V_{OUT} with a resistive voltage divider. This IC senses feedback voltage via FB and regulate it at 0.808V.
3	1	COMP	Compensation Pin. This pin is used to compensate the regulation control loop. Connect a series RC network from COMP pin to GND.
4	2	VCC5	LG Driver Bias Supply. Decouple with an 1uF capacitor.
5, 6, 7	3, 4, 5	VIN	Power Supply Input Pin. Drive 9V to 40V voltage to this pin to power on this chip. Connecting a 10uF ceramic bypass capacitor between VIN and GND to eliminate noise.
8	8	BS	High Side Gate Drive Boost Input. A 22nF or greater capacitor must be connected from this pin to SW. It can boost the gate drive to fully turn on the internal high side NMOS.
9, 10	9, 10	SW	Power Switching Output. It is the output pin that internal high side NMOS switching to supply power.
11	11	LG	Gate Driver Output. Connect this pin to the gate of the external low-side Power MOSFET.
12	12	OVP	OVP Input Pin. If the voltage at this pin is over 6.2V, the IC shuts down the high-side switching MOSFET.
13	13	GND	Ground Pin.
14	14	CS2	The output current of V_{OUT2} is sensed by this pin. When the voltage on this pin is over output 116mV for 750 μ s, the IC shuts down for 2.5 seconds before initiating a re-startup.
15	17	GND	Exposed Pad. Connecting to Pin 13.



Order Information

Part Number	Package	Shipment
TX9559FTR	QFN4*4-16L	Tape & Reel / 3000
TX9559TP14R	TSSOP14	Tape & Reel / 4000

Absolute Maximum Ratings⁽¹⁾

Input Supply Voltage V_{IN} -0.3V ~ 42V
 SW Voltage V_{SW} -0.3V(-5V for <10ns) ~ 42V (46V for < 5ns)
 Boost Voltage V_{BS} -0.3 ~ ($V_{SW} + 6V$)
 All Other Pins Voltage -0.3V ~ 6.5V
 Maximum Junction Temperature 150°C

Storage Temperature-55°C ~ 150°C
 Lead Temperature (Soldering 10sec)260°C
 ESD Classification(HBM)Class 2
 Power Dissipation (P_D)TSSOP-14 @ $T_A = 25^\circ C$ 2.5W
 Power Dissipation (P_D)QFN4*4-16@ $T_A = 25^\circ C$.. 2.63W

Recommended Operating Conditions⁽²⁾

Input Supply Voltage V_{IN} 9V ~ 40V

Ambient Temperature T_A -40°C~85°C

Thermal Characteristics

TSSOP-14, θ_{JA} 40°C/W

QFN4*4-16, θ_{JA} 38°C/W

Notes(1): Stresses exceed those ratings may damage the device.

Notes(2): If out of its operation conditions, the device is not guaranteed to function.



TX9559

<http://www.txsemi.com>

40V, 8A, 200kHz Step-Down Converter with Synchronous Gate Driver

Electrical Characteristics

$V_{IN}=12V$, $T_A=25^{\circ}C$, unless otherwise specified.

Parameter	Symbol	Test Conditions	Min	Typ	Max	Unit
V_{IN} Input Supply Voltage	---	---	9	---	40	V
Quiescent Current (non-switching)	I_Q	$V_{FB}=1V$	---	1.5	2	mA
Standby Supply Current (no loading)	---	---	---	6	---	mA
Feedback Voltage	V_{FB}	$9V \leq V_{IN} \leq 40V$	792	808	824	mV
High-Side MOSFET-On Resistance ⁽³⁾	$R_{DS(ON)1}$	At 25°C	---	40	---	mΩ
High-Side MOSFET Leakage Current	---	$V_{EN}=0V$, $V_{SW}=0V$	---	---	10	uA
High-Side MOSFET Current Limit ⁽³⁾	---	TX9559, Duty=65%	---	10	---	A
COMP to Current sense Transconductance	G_{CS}	---	---	4.6	---	A/V
Error Amplifier Transconductance	G_{EA}	$\Delta I_{COMP}=\pm 10\mu A$	---	650	---	$\mu A/V$
Error Amplifier Voltage Gain	A_{EA}	---	---	4000	---	V/V
Maximum Duty Cycle	D_{MAX}	$V_{FB}=0.7V$	---	80	---	%
Minimum On Time	T_{ON}	---	---	250	---	ns
Oscillation frequency	F_{OSC}	---	140	200	260	KHz
Input UVLO Threshold	---	V_{IN} Rising	---	7.3	8.3	V
Under Voltage Lockout Threshold Hysteresis	---	---	---	850	---	mV
OVP Pin Voltage	V_{OVP}	OVP Pin Voltage Rising	---	6.2	---	V
Soft-Start Period	---	---	---	10	---	mS
CS1 reference voltage	ΔV_{CS1}	$V_{OVP} - V_{OUT1}$	108	116	124	mV
CS2 reference voltage	ΔV_{CS2}	$V_{OVP} - V_{OUT2}$	108	116	124	mV
Cord Compensation		$V_{IN}=12V, R_1=200K, I_{OUT}=5A$	---	0.35	---	V
Thermal Shutdown Threshold ⁽³⁾	---	---	---	160	---	°C
LG Driver Bias Supply Voltage	V_{CC5}	---	4.5	5	---	V
Gate Driver Sink Impedance ⁽³⁾	R_{Sink}	---	---	0.9	---	Ω
Gate Driver Source Impedance ⁽³⁾	R_{Source}	---	---	3.3	---	Ω

Notes:(3) Guaranteed by design.



Applications Information

Output Voltage Setting

The output voltage V_{OUT} is set using a resistive divider from the output to FB. The FB pin regulated voltage is 0.808V. Thus the output voltage is:

$$V_{OUT} = 0.808 * (1 + \frac{R1}{R2})V$$

Table1 lists recommended values of R1 and R2 for most used output voltage:

V_{OUT}	R1	R2
5V	52.3K	10K
3.3V	30.9K	10K

Table1 Recommended Resistance Values

Place resistors R₁ and R₂ close to FB pin to prevent stray pickup

Input Capacitor Selection

The use of the input capacitor is controlling the input voltage ripple and the MOSFETS switching spike voltage. Because the input current to the step-down converter is discontinuous, the input capacitor is required to supply the current to the converter to keep the DC input voltage. The capacitor voltage rating should be 1.25 times to 1.5 times greater than the maximum input voltage. The input capacitor ripple current RMS value is calculated as:

$$I_{IN(RMS)} = I_{OUT} * \sqrt{D * (1 - D)}$$

Where D is the duty cycle and the value is V_{OUT} / V_{IN} . A low ESR capacitor is required to keep the noise minimum. Ceramic capacitors are better, but tantalum or low ESR electrolytic capacitors may also suffice. When using tantalum or electrolytic capacitors, a 0.1uF ceramic capacitor should be placed as close to the IC as possible

Output Capacitor Selection

The output capacitor is used to keep the DC output voltage and supply the load transient current. Low ESR capacitors are preferred Ceramic, tantalum or low ESR electrolytic capacitors can be used, depends on the output ripple requirement. Add a 100uF or 470uF low ESR electrolytic capacitor when

operated in high input voltage range ($V_{IN} > 20V$). It can improve the device's stability. The output ripple voltage ΔV_{OUT} is described as:

$$\Delta V_{OUT} = \frac{V_{OUT}}{f_s * L} * (1 - \frac{V_{OUT}}{V_{IN}}) * (R_{ESR} + \frac{1}{8 * f_s * C_2})$$

Where f_s is the switching frequency, L is the inductance value, V_{IN} is the input voltage, V_{OUT} is the output voltage, R_{ESR} is the equivalent series resistance value of the output capacitor, and the C_2 is the output capacitor. When using the ceramic capacitors, the R_{ESR} can be ignored and the output ripple voltage ΔV_{OUT} is shown as:

$$\Delta V_{OUT} = \frac{V_{OUT}}{8 * f_s^2 * L * C_2} * (1 - \frac{V_{OUT}}{V_{IN}})$$

When using tantalum or electrolytic capacitors, typically 90% of the output voltage ripple is contributed by the ESR of output capacitors. the output ripple voltage ΔV_{OUT} can be estimated as:

$$\Delta V_{OUT} = \frac{V_{OUT}}{f_s * L} * (1 - \frac{V_{OUT}}{V_{IN}}) * R_{ESR}$$

The characteristics of the output capacitor also affect the stability of the regulation system. TX9559 can be optimized for a wide range of capacitance and ESR values.

Inductor

The output inductor is used for store energy and filter output ripple current. A large value inductor will result in less ripple current and lower output ripple voltage. But the trade-off condition often happens between maximum energy storage and the physical size of the inductor. The first consideration for selecting the output inductor is to make sure that the inductance is large enough to keep the converter in the continuous current mode. That will lower ripple current and results in lower output ripple voltage. A good rule for determining the inductance is set the peak-to-peak inductor ripple current ΔI almost equal to 30% of the maximum load current. Then the minimum inductance can be calculated with the following equation:



$$L \geq \frac{V_{OUT}}{f_s \cdot \Delta I} * \left(1 - \frac{V_{OUT}}{V_{IN}}\right)$$

$$\Delta I = 0.3 * I_{LOAD(MAX)}$$

Where V_{IN} is the input voltage, f_s is the switching frequency, ΔI is the peak-to-peak inductor ripple current and $I_{LOAD(MAX)}$ is the maximum load current.

Choose an inductor that will cause the peak inductor current satisfying the equation:

$$I_{LP} = I_{LOAD(MAX)} + \frac{V_{OUT}}{2 * f_s * L} * \left(1 - \frac{V_{OUT}}{V_{IN}}\right) \leq I_{LIMIT}$$

Where I_{LIMIT} is the high-side MOSFET current limit value.

Rectifier Diode

During the transition between switching MOSFETs, a Schottky diode should be connected between SW pin and GND pin. The Schottky diode must have current rating higher than the maximum.

Compensation Components

The system stability and transient response are controlled through the COMP pin. Selecting the appropriate compensation value by the following procedure:

1. Calculate the R3 value with the following equation:

$$R3 < \frac{2\pi * C2 * f_s * V_{OUT}}{10 * G_{EA} * G_{CS} * V_{FB}}$$

2. where G_{EA} is the error amplifier transconductance, and G_{CS} is the current sense transconductance.

Calculate the C3 value with the following equation:

$$C3 > \frac{4 * 10}{2\pi * R3 * f_s}$$

3. If the C2 ESR zero is less than half of the switching frequency, use C6 to cancel the ESR zero:

$$C6 = \frac{C2 * R_{ESR}}{R3}$$

PCB Layout Recommendation

The device's performance and stability is dramatically affected by PCB layout. It is recommended to follow these general guidelines show below:

1. Keep the traces of the main current paths as short and wide as possible to minimize parasitic inductance and resistance.
2. Place VIN bypass capacitor (CIN) close to the device pins (VIN and GND). The loop area formed by CIN and VIN/GND pins must be minimized.
3. Place feedback resistors close to the FB pin. Connect feedback network behind the output capacitors.
4. Place compensation components close to the COMP pin.
5. Keep the sensitive signal (FB, COMP, CS1, CS2) away from the switching signal (SW).
6. Connect all analog grounds to a command node and then connect the command node to the power ground behind the output capacities.
7. The exposed pad of the package should be soldered to an equivalent area of metal on the PCB. This area should connect to the GND plane and have multiple via connections to the back of the PCB as well as connections to intermediate PCB layers. The GND plane area connects to the exposed pad should be maximized to improve thermal performance.
8. Multi-layer PCB design is recommended.



Typical Application Circuit

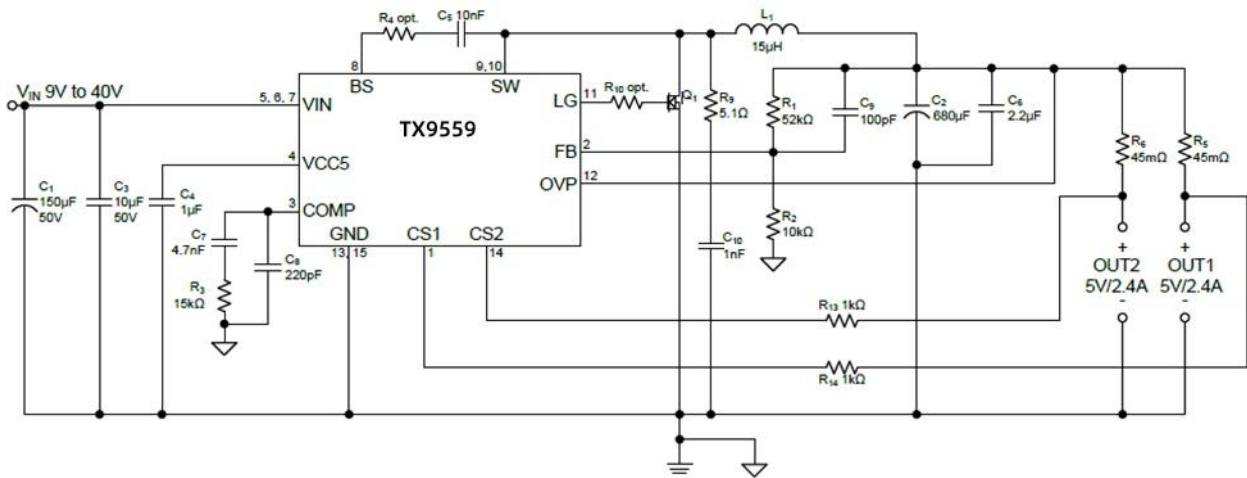
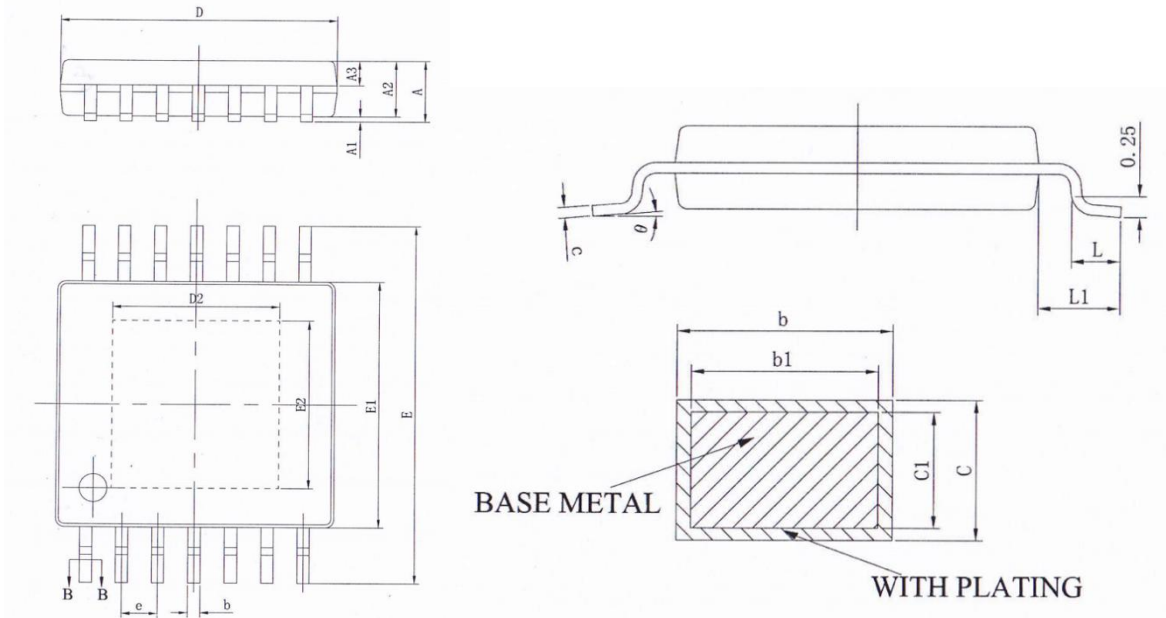

Figure 3 Application Circuit



TSSOP14 PACKAGE INFORMATION



SYMBOL	MILLIMETER			INCHES		
	MIN	NOM	MAX	MIN	NOM	MAX
A	---	---	1.2	---	---	0.047
A1	0.05	---	0.15	0.002	---	0.006
A2	0.80	0.90	1.05	0.031	0.035	0.041
L	0.45	0.60	0.75	0.018	0.024	0.030
E	6.40			0.2852		
E1	4.30	4.40	4.50	0.169	0.173	0.177
R	0.09	---	---	0.004	---	---
R1	0.09	---	---	0.004	---	---
b	0.19	---	0.30	0.007	---	0.012
b1	0.19	0.22	0.25	0.007	0.009	0.010
c	0.09	---	0.20	0.004	---	0.008
C1	0.09	---	0.16	0.004	---	0.006
L1	1.0			0.039		
e	0.65			0.026		
theta1	0	---	8°	0	---	8°
theta2	12°			12°		
theta3	---			12°		
D	4.90	5.00	5.10	0.193	0.197	0.201
D1	2.64	---	3.25	0.104	---	0.128
E2	2.55	---	3.15	0.100	---	0.124



QFN4*4-16L PACKAGE INFORMATION

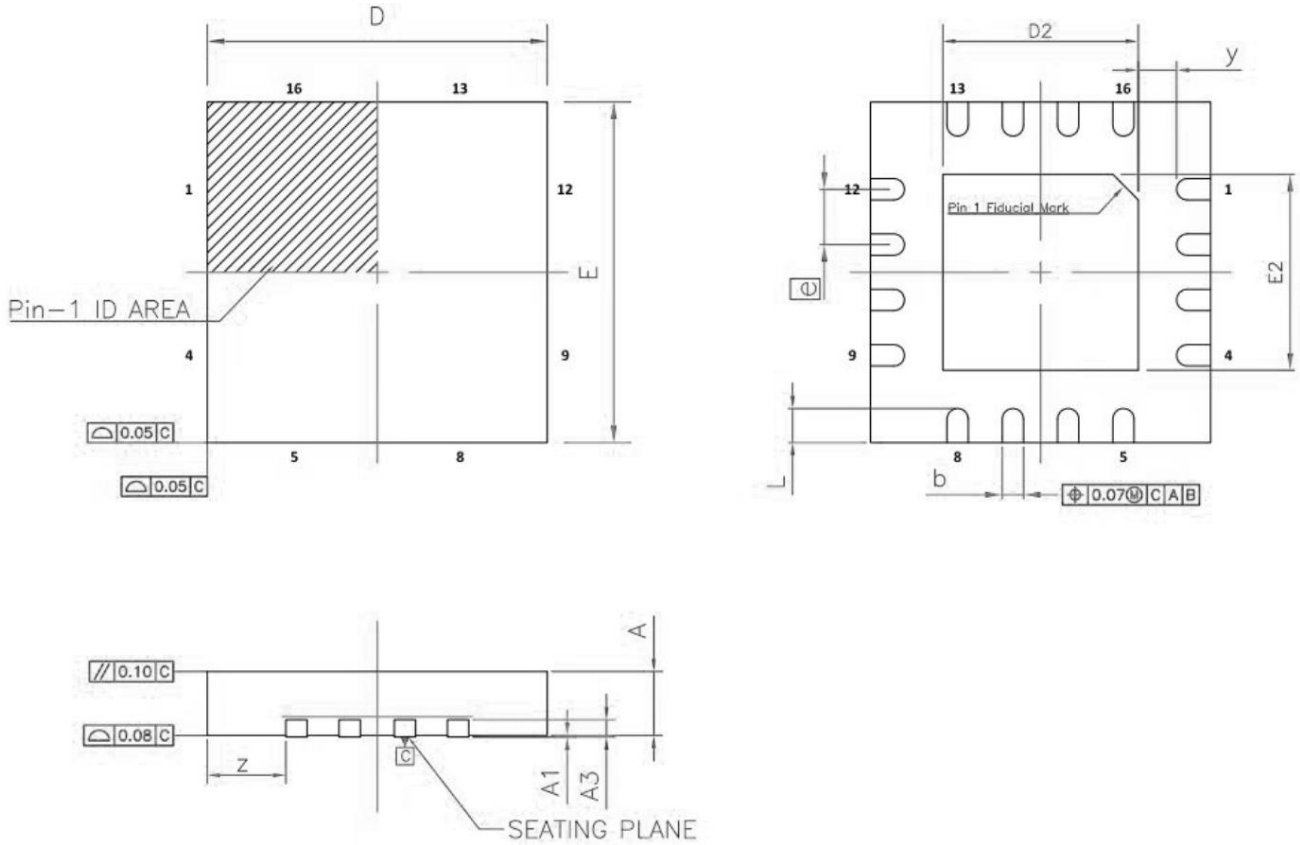

SYMBOL	MILLIMETER		
	MIN	NOM	MAX
D	3.95	4.00	4.05
E	3.95	4.00	4.05
D2	2.20	2.30	2.40
E2	2.20	2.30	2.40
A	0.70	0.75	0.80
A1	0.00	0.02	0.05
A3	0.203 REF		
b	0.20	0.25	0.30
e	0.650 BSC		
K	---	---	---
L	0.35	0.40	0.45
Y	0.450 REF		
Z	0.925 REF		



© Shanghai TX Semiconductor Sci.-Tech. Co., Ltd.

TX cannot assume responsibility for use of any circuitry other than circuitry entirely embodied in a TX product. No circuit patent license, copyrights or other intellectual property rights are implied. TX reserves the right to make changes to their products or specifications without notice. Customers are advised to obtain the latest version of relevant information to verify, before placing orders, that information being relied on is current and complete.